

# Comprehensive Study of Different ROF Modulation Schemes in Optical Fiber Communication

Srinivas Babu .P<sup>1</sup> and Dr.Prahlad.T.Kulkarni<sup>2</sup>

<sup>1</sup>Department of Telecommunication, Dayananda Sagar College of Engineering, Bangalore -560078, India  
E-mail : psrinivasbabu@gmail.com

<sup>2</sup>Senior Member IEEE, Principal, Dept of Telecommunication, Pune Institute of Computer Technology, Pune-411043, India  
E-mail : ptkul@ieee.org

**Abstract**—The ever growing broadband internet applications have increased the traffic capacity and demand for wide network coverage. Radio over fiber (ROF) is a combination of Wireless as front end and Optical Fiber Communication as Back-haul networks. ROF network provides mobility for users with high quality bandwidth and better geographical access. In this paper, we analyze Q-factor, BER & eye patterns for various Modulation schemes such as MSK, DPSK, OQPSK, CPFSK and Q-CPFSK (Quadrature) by means of Bit-rate and fiber length. Our Simulation results shows that Q-CPFSK gives better performance compared to other schemes at Optical Carrier Frequency of 193.1THz.

**Index Terms**— ROF, MZM, APD, MSK, DPSK, OQPSK, CPFSK, and Q-CPFSK.

## I. INTRODUCTION

ROF radiates RF signal from central station to remote antennas via Base station and back to Central station with high bandwidth and data rates. ROF possess wide bandwidth, low loss and low attenuation. It is immune to Radio frequency interference, provides multiple services and Resource allocation. It is widely used for internet applications like VOIP, streaming videos and Video-on-Demand which results in high burst traffic issues. ROF consists of a Duplex-link (for both upward and downward) transmission down the length for high efficient bandwidth [1].

A Real-time ROF system is as shown in fig 1. During Down-link transmission, the RF signal is intensity modulated by the laser diode and sent to the base station via an Optical fiber. At the base station, the signal is demodulated using a photodiode which is later amplified and radiated in all directions by using an antenna. In Up-link transmission, the opposite process takes place. The laser diode modulates the RF signal which is received from the antenna and is then sent to the Central station over an optical fiber. At the Central station, the signal is demodulated using a photodiode and the signal is processed further.[2][3]. The various types of Modulation schemes are DPSK, OQPSK, MSK, CPFSK and Q-CPFSK respectively.

## II. ROF WORKING DESIGN

The base-band signal  $f_b$  from the PRBS generator is modulated using a high frequency RF carrier wave  $f_c$  and is then electrically modulated using DPSK, OQPSK, MSK, CPFSK and Q-CPFSK schemes respectively. The

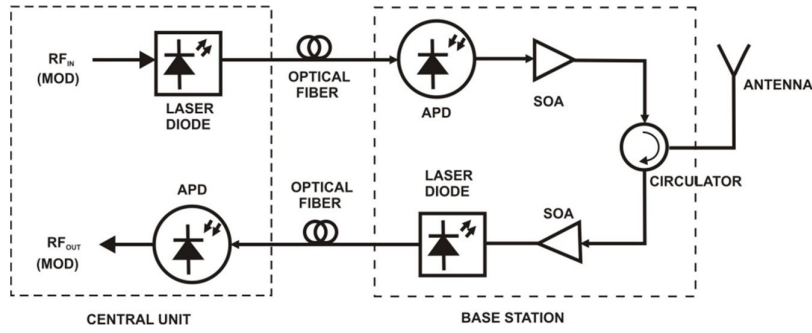

Fig 1. A Real-time ROF System

unwanted Frequency components of the modulated signal is removed by the Band Pass Filter. The resulting signal is then optically modulated using a laser diode of frequency  $f_o$  and Mach-Zehnder Modulator (MZM). Due to Optical Modulation, the upper sideband frequency of the resulting signal now becomes  $(f_o + f_c)$ . The Lower and Upper frequencies of this upper sideband becomes  $(f_o + f_c \pm f_{b1})$  and  $(f_o + f_c \pm f_{b2})$ [4]. The upper sideband is then filtered using Optical Band Pass Filter (OBPS) which has frequency  $(f_o + f_c)$  and bandwidth of  $(1.5 * f_b)$  (Bit Rate)).

The signal is then sent through and APD (Avalanche Photo diode) and LPF (Low Pass filter) where the optical signal is demodulated and converted back to the baseband signal. The LPF removes the high frequency component and the output is visualized on an Optical Spectrum Analyzer to obtain the BER and Eye diagram [5], [6].

### III. SIMULATION SETUP

The simulation setup for MSK, DPSK, OQPSK, CPFSK and Q-CPFSK Modulation schemes are as shown in fig 2(a), 2(b), 2(c), 2(d), 2(e) & 2(f). The system is designed for two users in which two PRBS generators are used for modulating the digital signals.

#### A. MSK Modulation Scheme

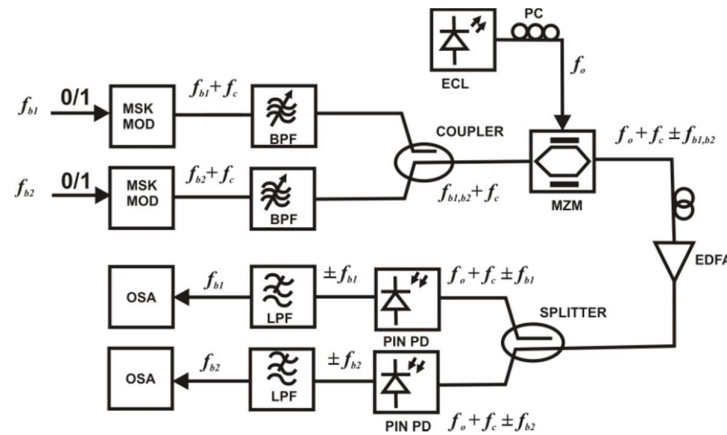

Fig 2(a). ROF Modulation using MSK

MSK is a kind of Binary CPFSK with modulation index being  $h = 1/5$ . The data from two PRBS generator is fed to two MSK Modulators operating at 250 GHz and 255 GHz. It is then fed to Optical Bandpass filter and then coupled to Mach-Zehnder Modulator for external modulation. A laser diode of optical carrier frequency 193.1 THz is used for optical modulation. This modulated signal is later amplified and passed through a splitter[7] at two different frequencies. The optical signals are filtered using Band-pass filter with frequencies 193.119 THz and 193.120 THz at Bandwidth =  $1.5 * f_b$  (Bit Rate) respectively. The Low Pass Filter with Cut-off frequency =  $0.75 * \text{Bit Rate}$  (Hz) is used for filtering the High Frequency Components. The resulting output is visualized on an Optical Spectrum Analyzer[8], [9], [10].

### B. DPSK Modulation scheme

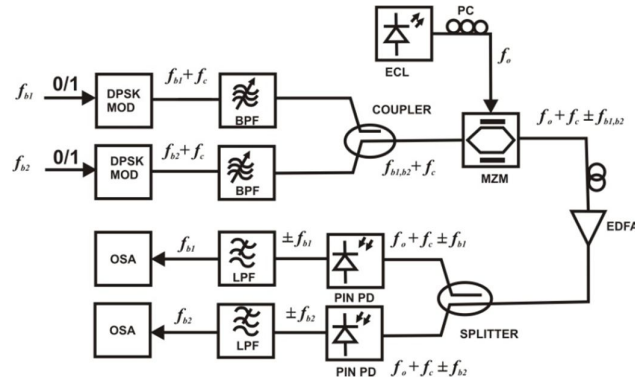

Fig 2(b). ROF Modulation using DPSK

DPSK is a non-coherent version of PSK scheme. The received signal is a combination of two operations which is the

(1) Binary Input with Differential Encoding and (2) Phase shift keying.

To send symbol '0', the carrier is phase shifted by  $180^\circ$  and to send symbol '1', the carrier phase remains unchanged over the duration  $0 \leq t \leq 2T_b$ .

The data from two PRBS generator is fed to two DPSK Modulators operating at 250 GHz and 255 GHz. It is then fed to Optical Bandpass filter and then coupled to Mach-Zehnder Modulator for external modulation. A laser diode of Optical Carrier Frequency 193.1 THz is used for Optical Modulation This modulated signal is later amplified and passed through a splitter at two different frequencies. The optical signals are filtered using Band-pass filter with frequencies 193.119 THz and 193.120 THz at Bandwidth =  $1.5 * f_b$  (Bit Rate) respectively. The Low Pass Filter with Cut-off frequency =  $0.75 * \text{Bit Rate}$  (Hz) is used for filtering the High Frequency Components. The resulting output is seen on an Optical Spectrum Analyzer .

### C. OQPSK Modulation Scheme

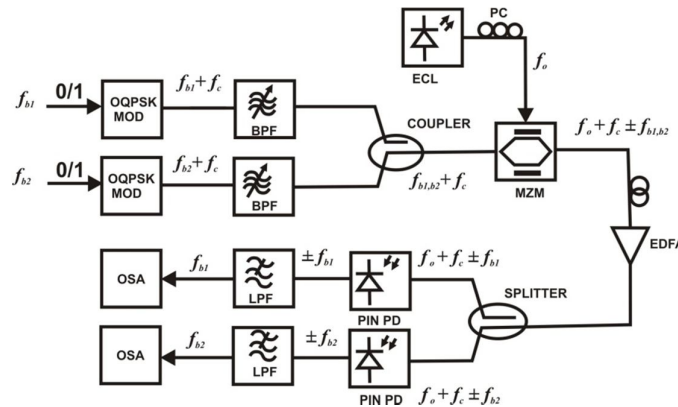

Fig 2(c). ROF Modulation using OQPSK

OQPSK is a type of QPSK in which the signal is transmitted without amplitude modulation. The incoming signal in the modulator is consists of two types namely I and Q which are transmitted by shifting it by an interval of half symbol duration. There is no phase shifting of  $180^\circ$  during Zero crossing as in the case of standard QPSK.

The data from two PRBS generator is fed to two OQPSK Modulators operating at 250 GHz and 255 GHz. It is then fed to Optical Bandpass filter and then coupled to Mach-Zehnder Modulator for external modulation. A laser diode of Optical Carrier Frequency 193.1 THz is used for Optical Modulation This modulated signal is later amplified and passed through a splitter at two different frequencies. The optical signals are filtered using Band-pass filter with frequencies 193.119 THz and 193.120 THz at Bandwidth =  $1.5 * f_b$  (Bit Rate)

respectively. The Low Pass Filter with Cut-off frequency =  $0.75 * \text{Bit Rate (Hz)}$  is used for filtering the High Frequency Components. The resulting output is visualized on an Optical Spectrum Analyzer.

#### D. CPFSK Modulation Scheme

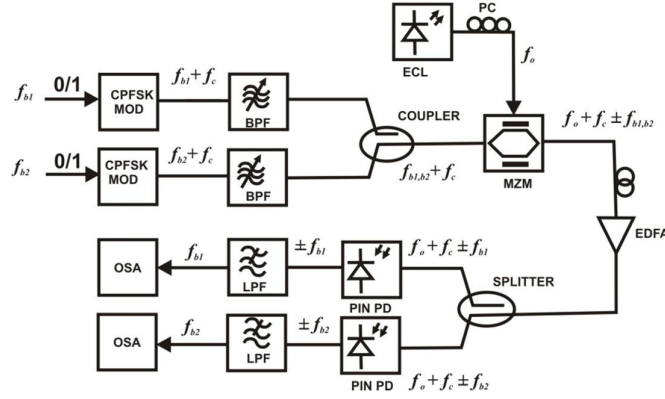

Fig 2(d). ROF Modulation using CPFSK

CPFSK is memory based modulation scheme in which phase is maintained continuous. The data from two PRBS generator is fed to two CPFSK Modulators operating at 250 GHz and 255 GHz. It is then fed to Optical Bandpass filter and then coupled to Mach-Zehnder Modulator for external modulation. A laser diode of Optical Carrier Frequency 193.1THz is used for Optical Modulation This modulated signal is later amplified and passed through a splitter at two different frequencies. The optical signals are filtered using Band-pass filter with frequencies 193.119 THz and 193.120 THz at Bandwidth =  $1.5 * f_b$  (Bit Rate) respectively. The Low Pass Filter with Cut-off frequency =  $0.75 * \text{Bit Rate (Hz)}$  is used for filtering the High Frequency Components. The resulting output is seen on an Optical Spectrum Analyzer.

#### E. Q-CPFSK Modulation Scheme

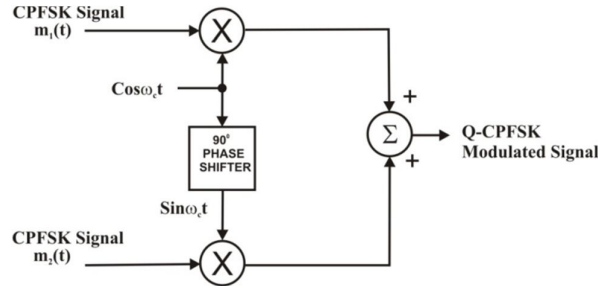

Fig 2(e) Quadrature Modulator

In this method, two different message signals  $m_1(t)$  and  $m_2(t)$  from CPFSK Modulator are fed to a Quadrature Modulator as input. The Carrier  $\text{Cos}(\omega_c t)$  is phase shifted by  $90^\circ$  to give  $\text{Sin}(\omega_c t)$  which are Orthogonal to each other. Since  $m_1(t)$  and  $m_2(t)$  are two identical CPFSK signals, the Carrier Modulated signal can be expressed as

$$v(t) = \sqrt{\frac{2E_b}{T_b}} \cos[\omega_c t + (2j - 1) \frac{\pi}{4} + \varphi(t; A) + \varphi_o] \quad (1)$$

Where  $\omega_c$  is the Carrier frequency,  $E_b$  is the Symbol Energy,  $T_b$  is the Symbol period,  $\varphi_o$  is an arbitrary constant phase offset and  $\varphi(t; A)$  represents the time- varying carrier phase given by

$$\varphi(t; A) = 2\pi h \int_0^t \sum_n I_n p(\tau - nT) d\tau \quad (2)$$

Where  $h$  is the Modulation Index given by  $h = m/n$ ,

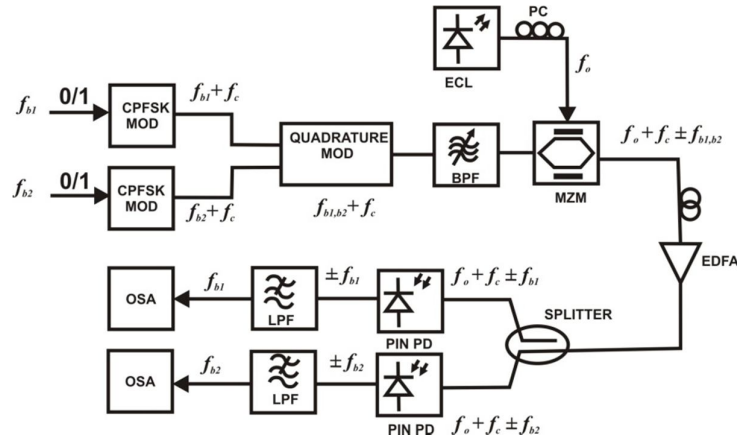

Fig 2(f) ROF Modulation using Q-CPFSK

(m and n being positive integers) and p(t) being a Rectangular pulse of width T given by

$$p(t) = \begin{cases} \frac{t}{2T} & 0 \leq t \leq T \\ 0 & t > T \end{cases} \quad (3)$$

As shown in the circuit diagram, two CPFSK Modulators are connected to a Quadrature Modulator and then to a Band pass filter which is in turn connected to Mach-Zehnder Modulator for external modulation. The remaining working procedure is same as CPFSK Modulator scheme.

#### IV. SIMULATION RESULT

The Quality factor, Bit Error Rate Analysis and Eye diagram for MSK, DPSK, OQPSK, CPFSK and Q-CPFSK schemes has been shown in figs 3(a), 3(b), 3(c), 3(d) & 3(e) respectively. The RF Spectrum Analysis for MSK, DPSK, OQPSK, CPFSK and Q-CPFSK schemes has been shown in figs 4(a), 4(b), 4(c), 4(d) & 4(e) respectively. The same has been summarized in Table I. Higher the Q-Factor, more will be the number of users in the system. The result analysis shows that Q-CPFSK Modulation scheme is the best for ROF system in terms of high Q-Factor and Minimum BER. The eye height of Q-CPFSK is higher compared to other schemes.

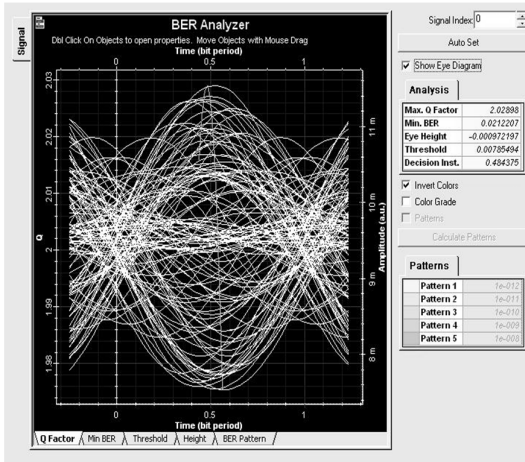

Fig 3(a). BER Analysis for ROF using MSK

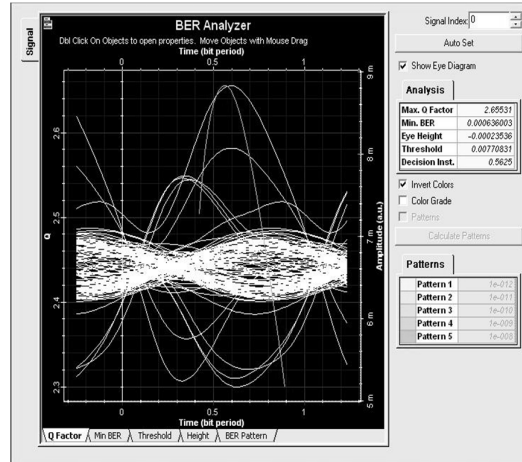

Fig 3(b). BER Analysis for ROF using DPSK

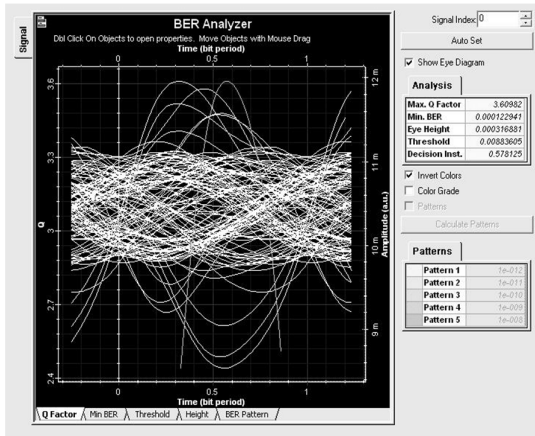

Fig 3(c). BER Analysis for ROF using OQPSK

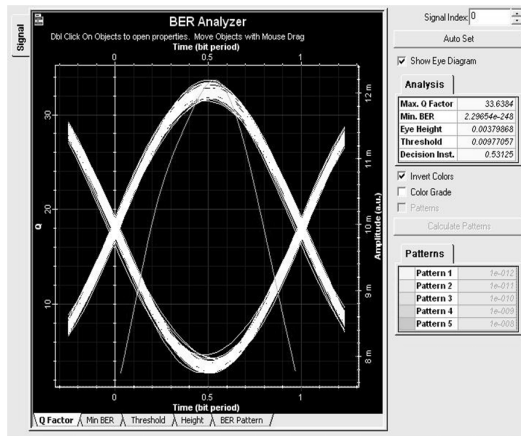

Fig 3(d). BER Analysis for ROF using CPFSK

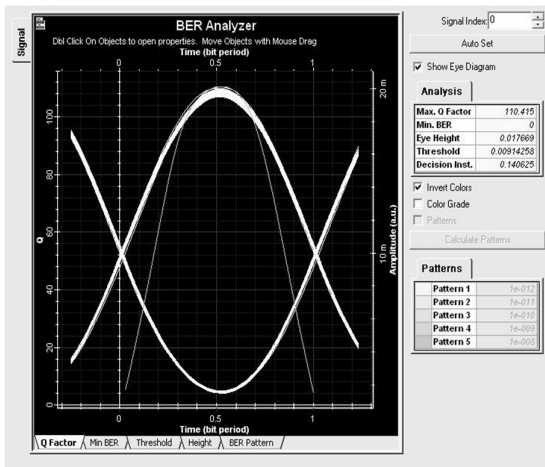

Fig 3(e). BER Analysis for ROF using Q-CPFSK

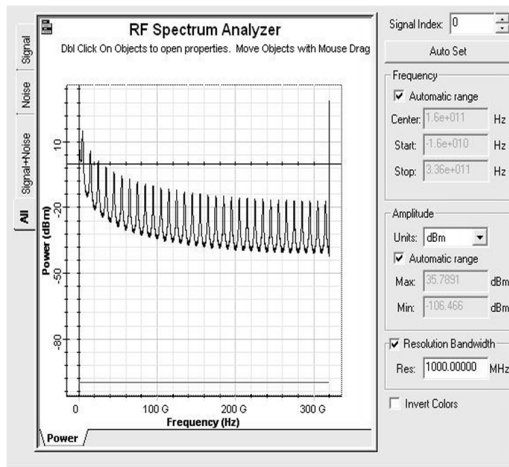

Fig 4(a). RF Spectrum Analysis for ROF using MSK

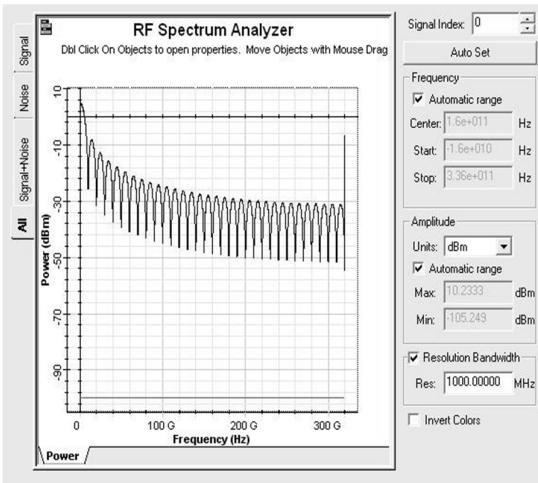

Fig 4(b). RF Spectrum Analysis for ROF using DPSK

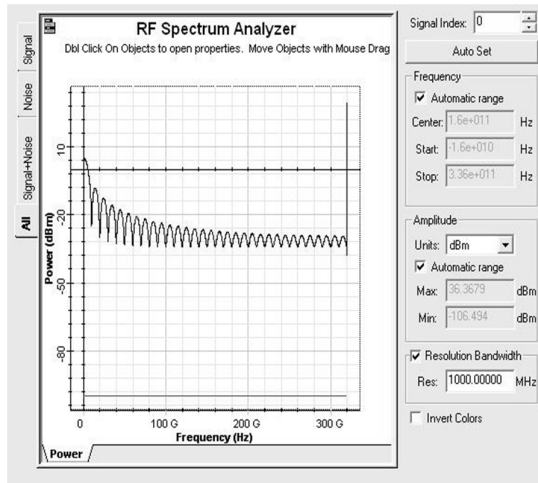

Fig 4(c). RF Spectrum Analysis for ROF using OQPSK

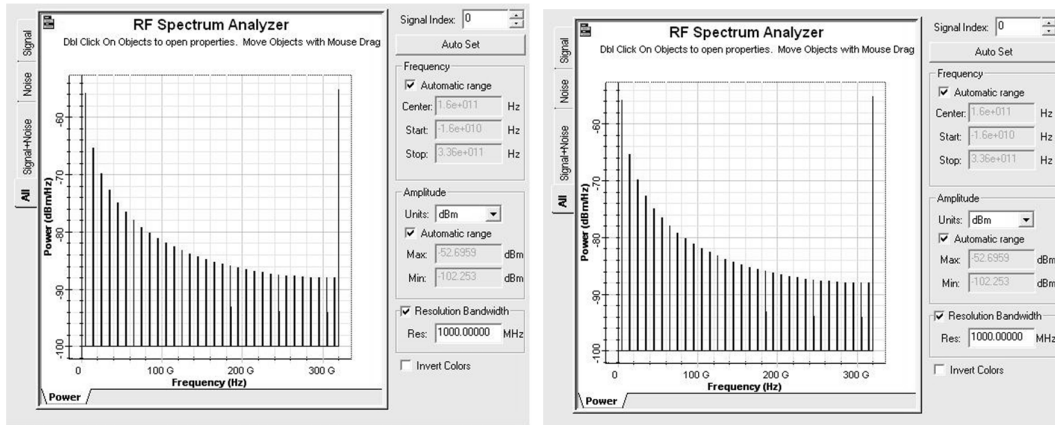

Fig 4(d). RF Spectrum Analysis for ROF using CPFSK

Fig 4(e). RF Spectrum Analysis for ROF using Q-CPFSK

From the RF spectrum analysis, we see that Power density of CPFSK and Q-CPFSK are much narrower compared to MSK and other schemes. A narrow spectrum is more advantageous compared to broader spectrum in terms of speed and bandwidth. Hence Q-CPFSK is more preferable than others. Also the power spectrum decays exponentially with increase in frequency.

TABLE I. SIMULATION RESULTS OF VARIOUS ROF MODULATION SCHEMES

| Modulation Schemes |          |                          |                           |                             |         |
|--------------------|----------|--------------------------|---------------------------|-----------------------------|---------|
| Parameter          | MSK      | DPSK                     | OQPSK                     | CPFSK                       | Q-CPFSK |
| Maximum Q- Factor  | 2.66     | 3.61                     | 2.03                      | 33.64                       | 110.4   |
| Minimum BER        | 0.021    | 0.64<br>$\times 10^{-3}$ | 0.123<br>$\times 10^{-3}$ | 0.229<br>$\times 10^{-247}$ | 0       |
| Threshold          | 0.0078   | 0.0077                   | 0.0088                    | 0.0098                      | 0.0092  |
| Eye Height         | -0.00097 | -0.00024                 | 0.00032                   | 0.0038                      | 0.018   |

## V. CONCLUSION

The ROF was designed and simulated using commercially available Optisystem 14.0 Software and the parameters such as Q-Factor, BER and eye diagrams were compared for different Modulation Schemes such as MSK, DPSK, OQPSK, CPFSK and Q-CPFSK. Form these, Q-CPFSK has shown better performance compared to others thereby eliminating the need for electrical demodulation at the receiver section. Optical signal is directly converted into baseband signal using only one Optical Demodulator thereby making it cheaper and more economical compared to conventional methods.

## REFERENCES

- [1] Sarra Rebhi, Rim Barrak, Mourad Menif "A Multistandard and Multiservice Radio over Fiber System for Next Generation Networks" 5th International Conference on Multimedia Computing and Systems (ICMCS), 2016
- [2] Latifa Guesmi and Mourad Menif, "Modulation Formats Recognition Technique Using Artificial Neural Networks for Radio over Fiber Systems" ICTON 2015
- [3] H.A. Mohammad , Performance evaluation of DWDM for Radio over Fiber system with Dispersion Compensation and EDFA , International Journal of Computer Applications, Vol.72, No.10,June 2013.
- [4] J.Johny , S.Shashidharan , Design and Simulation of a Radio Over Fiber System and its Performance Analysis, Optical Networking Technologies and Data Security- OPNTDS, 2012.
- [5] A.M. Zin , S.M. Idrus , The characterization of Radio over Fiber Employed GPON Architecture for Wireless Distribution Network , International Journal of Machine Learning and Computing, Vol.1, No.5 , December 2011.

- [6] S.M.J Alam , M.R. Alam , Bit Error Rate Optimization in Fiber Optic Communications , International Journal of Machine Learning and Computing, Vol.1, No.5, December 2011.
- [7] C.K. Wing , Y.Min, Radio-Over-Fiber 16-QAM , 100 km Transmission at 5Gb/s Using DSB-SC Transmitter and Remote Heterodyne Detection, Journal of Lightwave technology, Vol.26, No.6, March 15 ,2008.
- [8] A.M.J. Koonen , M.G. Larode , Perspectives of Radio over Fiber Technologies, OFC/NFOEC , 2008.
- [9] S.C.Chan, S.K. Hwang, J.M. Lin, Radio-over-Fiber AM-to-FM up conversion using an optically injected semiconductor laser, Optics Letters, Vol.31, No.15, August1 , 2006.
- [10] H.B. Kim, M.Emmelmann, A Radio over Fiber Network Architecture for Road Vehicle Communication Systems, Proc. 47th IEEE Vehicular Technology Conference, 2005.